

JD Manufacturing Inc

Specializing in process automation and control

As specialists in process automation and control, we understand that every application has unique challenges. This is why we custom build every piece of equipment to fit your needs. Off-the-shelf products often create as many problems as they solve, causing labor intensive situations that eat into your profits. Our equipment is designed around powerful microprocessor based controllers to provide maximum flexibility for optimum product quality. Microprocessor controls make it easy for authorized personnel to make programming changes, and eliminates unauthorized tampering. Our fryers, stirrers, conveyors, ovens, seasoning and extractor processes have been field-tested. They work flawlessly and look exceptional after years of rigorous service. Our years of experience in the food process business give us a distinct advantage over other companies. We know the reality of production and sanitation problems. We design our equipment to be trouble-free and easy to clean. Let us equip you with state of the art processes that will minimize your labor expenses and maximize your profits while giving you peace of mind.

This is an automated frying process. Our unique design causes positive product separation which virtually eliminates clusters and soft centers. We creatively designed our stirrers and fryers so that we don't have any motors or wiring above the fryer. Our stirring units have an open design to make them simple to clean. Floor level operation makes maintenance and sanitation easy. We are now equipping our fryers with a fine removal mechanism to further improve cleaning.



JD Manufacturing Inc
309 Butler Ave, PO Box 279
Pine Bluffs, Wyoming 82082 USA
Phone: (307)245-3779 Fax: (307)245-3480
Email: info@jdmanufacturinginc.com
www.jdmanufacturinginc.com

JD Manufacturing Inc

Standard Equipment

- All stainless steel construction
- Automated nonstick stirring unit
- PLC and Touch screen controls for greater flexibility
- Direct fired high efficiency burner system
- Fully variable drive speeds
- Remote mount control panel
- Tilt out takeout conveyor with stainless belt
- Oil level control (Ultrasonic or Capacitive)
- Flue Temperature Monitoring

Optional Equipment

- Fine removal system
- Automatic takeout conveyor tilt mechanism
- Bottom stirring setup for sinking/semi buoyant products
- Extended takeout conveyor for superior oil drainage
- Kosher heater
- Operator platform
- Takeout conveyor product rejection chute

Specifications

- Power:
 - ◆ 230/460 Volt, 3 Phase, 15/8 amps
 - ◆ US380/415 Volt, 3 Phase, EU
- Control:
 - ◆ 115 Volt Single Phase, 15 amps
 - ◆ 220 Volt Single Phase EU
- Air:
 - ◆ 100 psi, < CFM
- Gas:
 - ◆ 3,000,000 BTU Natural Gas/Propane/Butane
 - ◆ Maxon 8-15 TOF Burners/Comtherm TF8 Burners
 - ◆ 6.3 Inch Water Column, 15.69 MBAR
 - ◆ Combustion Air 520 Cubic Feet/Minute
- Exhaust:
 - ◆ 12 Inch US/300mm EU
 - ◆ 605 CFM/M.BTU
- Weight:
 - ◆ 3480 lbs/ 1582

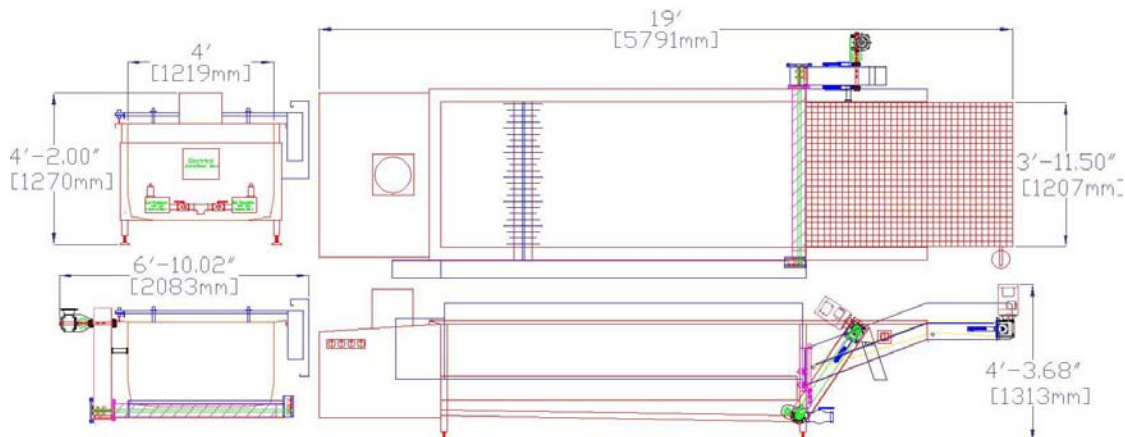

JD Manufacturing Inc
309 Butler Ave, PO Box 279
Pine Bluffs, Wyoming 82082 USA
Phone: (307)245-3779 Fax: (307)245-3480
Email: info@jdmanufacturinginc.com
www.jdmanufacturinginc.com